



## Forno elettrico a convezione

Electrical convection oven

Four à convection électrique

Elektro-Konvektionsofen

Horno eléctrico de convección

Serie  
Line  
Série  
Modell  
Serie

Cod. 14100488 - **FCE5-UM\***

## FCE5-UM

### Caratteristiche e vantaggi

- Tecnologia a convezione con inversione automatica delle ventole - cottura uniforme
- Capacità 5 bacinelle Gastronorm GN 1/1 / griglie per FCE5; distanza guide 65 mm
- Attacco acqua 3/4"
- Porta con doppio vetro di sicurezza
- Illuminazione interna
- Regolazione della temperatura manuale con umidificatore, optional regolazione con scheda elettronica

### Characteristics and advantages

- Convection technology for automatic reversing of the fans - uniform cooking
- Capacity 5 Gastronorm trays GN 1/1 / grids for FCE5; slides distance 65 mm
- Water connection 3/4"
- Door with double safety glass
- Interior lighting
- Manual temperature adjustment with humidifier, optional regulation with electronic card

### Caractéristiques et avantages

- Technologie à convection, inversion automatique des ventilateurs - cuisson uniforme
- Capacité 5 bacs Gastronorm GN 1/1 / grilles pour FCE5; distance entre les guides 65 mm
- Connexion eau 3/4"
- Porte double vitrage de sécurité
- Illumination interne
- Réglage manuel de la température avec humidificateur, réglage par carte électronique en option

### Merkmale und Vorteile

- Konvektionstechnologie mit automatisch invertierenden Ventilatoren - gleichmäßiges Garen
- Kapazität 5 Gastronorm Behältern GN 1/1 oder 5 Roste für FCE5; Schienenabstand 65mm
- Wasseranschluß 3/4"
- Tür mit doppeltem Sicherheitsglas
- Innenbeleuchtung
- Manuelle Temperatureinstellung mit Luftbefeuchter, optionale Regulierung dank elektronischer Steuerung

### Características y ventajas

- Tecnología de convección con ventiladores reversibles - cocción uniforme
- Capacidad 5 bandejas Gastronorm GN 1/1 / rejillas para FCE5; distancia entre las bandejas 65 mm
- Conexión de agua 3/4"
- Puerta con doble acristalamiento
- Iluminación interior
- Ajuste manual de la temperatura con humidificador, opcional regulación con tarjeta electrónica



\* Senza griglie e senza bacinelle  
\* Without grids and without Gastronorm trays  
\* Sans grilles et sans bacs Gastronorm  
\* Ohne Roste und ohne Gastronorm Behälter  
\* Sin rejillas y sin bandejas Gastronorm

\* Con umidificatore  
\* With humidifier  
\* Avec humidificateur  
\* Mit Befeuchter  
\* Con humidificador





# FCE5-UM

**Accessori  
Optionals  
Accessoires  
Zubehör  
Accesorios**

	<b>Bacinella Gastronorm, GN1/1 H20 mm</b> Gastronorm tray Bac Gastronorm Gastronorm Behälter Bandeja Gastronorm	<b>Cod. 10040038</b>		<b>Bacinella Gastronorm, GN1/1 H40 mm</b> Gastronorm tray Bac Gastronorm Gastronorm Behälter Bandeja Gastronorm	<b>Cod. 10040021</b>
	<b>Griglia GN1/1</b> Grid Grille Rost Rejilla	<b>Cod. 10040058</b>			

**Info tecnica  
Technical info  
Infos techniques  
Technische Info  
Info técnica**

	230V 3~	400V 3N~
<b>Tipo presa</b> Socket Prise Anschlussdose Toma de enchufe	<b>32 A (3P+T)</b>	<b>16 A (3P+N+T)</b>
<b>Collegamento elettrico</b> Electrical connection Connexion électrique Elektrische Anschlüsse Conexión eléctrica	<b>Corrente max. 18 A Max. Voltage 18 A Courant max. 18 A Max. Strom 18 A Voltaje máx. 18 A</b>	<b>Corrente max. 12 A Max. Voltage 12 A Courant max. 12 A Max. Strom 12 A Voltaje máx. 12 A</b>
<b>Collegamento idrico</b> Water connection Raccordement d'eau Wasseranschluss Conexión de agua	<b>Attacco 3/4"</b> Water connection 3/4" Raccordement d'eau 3/4" Wasseranschluss 3/4" Conexión de agua 3/4"	
<b>Cavi di alimentazione</b> Power Cables Câbles d'alimentation Stromkabel Cables de alimentación	<b>1</b>	
<b>Capacità teglie</b> Capacity plates Capacité plats Fassungsvermögen Pfannen Capacidad bandejas	<b>5 (GN 1/1)</b>	

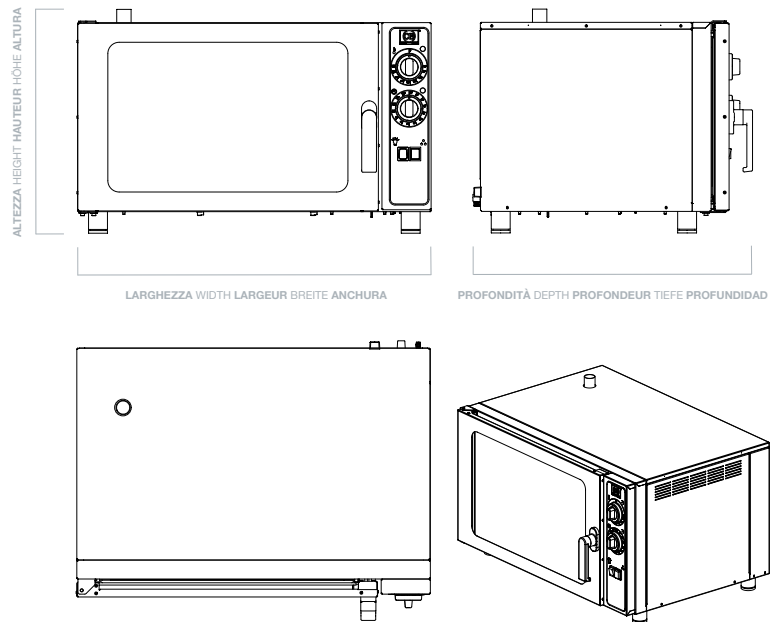

Modello Model Modèle Modell Modelo	Larghezza Width Largeur Breite Anchura	Profondità Depth Profondeur Tiefe Profundidad	Altezza Height Hauteur Höhe Altura	Capacità teglie GN 1/1 Capacity plates GN 1/1 Capacité plats GN 1/1 Fassungsvermögen Pfannen GN 1/1 Capacidad bandejas GN 1/1	Temperatura Temperature Température Temperatur Temperatura	Tensione Voltage Tension Spannung Voltaje	Potenza Power Puissance Leistung Potencia	Peso Weight Poids Gewicht Peso
<b>FCE5-UM</b>	935 mm	680 mm	560 mm	5	30° - 280°C	230V 3~ / 400V 3N~	5,7 KW	Kg 62