



Forno elettrico a convezione

Electrical convection oven

Four à convection électrique

Elektro-Konvektionsofen

Horno eléctrico de convección

Serie
Line
Série
Modell
Serie

Cod. 14100556 - **FCE10-UM PR9***

FCE10-UM PR9

Caratteristiche e vantaggi

- Tecnologia a convezione con inversione automatica delle ventole - cottura uniforme
- Capacità 10 bacinelle Gastronorm GN 1/1 / griglie per FCE10, distanza guide 80 mm
- Attacco acqua 3/4"
- Porta con doppio vetro di sicurezza
- Illuminazione interna
- Regolazione della temperatura manuale con umidificatore, optional regolazione con scheda elettronica

Characteristics and advantages

- Convection technology for automatic reversing of the fans - uniform cooking
- Capacity 10 Gastronorm trays GN 1/1 / grids for FCE10, slides distance 80 mm
- Water connection 3/4"
- Door with double safety glass
- Interior lighting
- Manual temperature adjustment with humidifier, optional regulation with electronic card

Caractéristiques et avantages

- Technologie à convection, inversion automatique des ventilateurs - cuisson uniforme
- Capacité 10 bacs Gastronorm GN 1/1 / grilles pour FCE10, distance entre les guides 80 mm
- Connexion eau 3/4"
- Porte double vitrage de sécurité
- Illumination interne
- Réglage manuel de la température avec humidificateur, réglage par carte électronique en option

Merkmale und Vorteile

- Konvektionstechnologie mit automatisch invertierenden Ventilatoren - gleichmäßiges Garen
- Kapazität 10 Gastronorm Behältern GN 1/1 oder 10 Roste für FCE10, Schienenabstand 80 mm
- Wasseranschluß 3/4"
- Tür mit doppeltem Sicherheitsglas
- Innenbeleuchtung
- Manuelle Temperatureinstellung mit Luftbefeuchter, optionale Regulierung dank elektronischer Steuerung

Características y ventajas

- Tecnología de convección con ventiladores reversibles - cocción uniforme
- Capacidad 10 bandejas Gastronorm GN 1/1 / rejillas para FCE10, distancia entre las bandejas 80 mm
- Conexión de agua 3/4"
- Puerta con doble acristalamiento
- Iluminación interior
- Ajuste manual de la temperatura con humidificador, opcional regulación con tarjeta electrónica

- * Senza teglie
- * Without plates
- * Sans plats
- * Ohne Pfannen
- * Sin bandejas

- * Con scheda elettronica e umidificatore
- * Electronic version with humidifier
- * Avec carte électronique et humidificateur
- * Mit elektronischer Ausführung und Befeuchter
- * Con programador electrónico y humidificador





FCE10-UM PR9

**Accessori
Optionals
Accessoires
Zubehör
Accesorios**

	Bacinella Gastronorm, GN1/1 H20 mm Gastronorm tray Bac Gastronorm Gastronorm Behälter Bandeja Gastronorm	Cod. 10040038		Bacinella Gastronorm, GN1/1 H40 mm Gastronorm tray Bac Gastronorm Gastronorm Behälter Bandeja Gastronorm	Cod. 10040021
	Griglia GN1/1 Grid Grille Rost Rejilla	Cod. 10040058			

**Info tecnica
Technical info
Infos techniques
Technische Info
Info técnica**

	230V 3~	400V 3N~
Tipo presa Socket Prise Anschlussdose Toma de enchufe	2x32 A (3P+T)	2x16 A (3P+N+T)
Collegamento elettrico Electrical connection Connexion électrique Elektrische Anschlüsse Conexión eléctrica	Corrente max. 2x18 A Max. Voltage 2x18 A Courant max. 2x18 A Max. Strom 2x18 A Voltaje máx. 2x18 A	Corrente max. 2x12 A Max. Voltage 2x12 A Courant max. 2x12 A Max. Strom 2x12 A Voltaje máx. 2x12 A
Collegamento idrico Water connection Raccordement d'eau Wasseranschluss Conexión de agua	Attacco 3/4" Water connection 3/4" Raccordement d'eau 3/4" Wasseranschluss 3/4" Conexión de agua 3/4"	
Cavi di alimentazione Power Cables Câbles d'alimentation Stromkabel Cables de alimentación	2	
Capacità teglie Capacity plates Capacité plats Fassungsvermögen Pfannen Capacidad bandejas	10 (GN 1/1)	

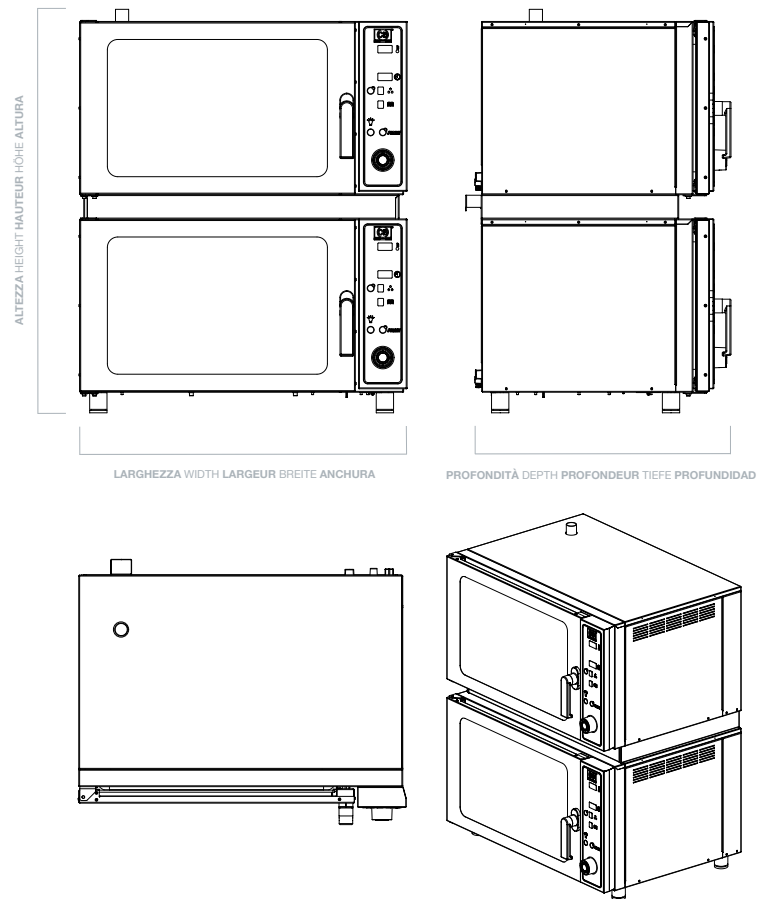

Modello Model Modèle Modell Modelo	Larghezza Width Largeur Breite Anchura	Profondità Depth Profondeur Tiefe Profundidad	Altezza Height Hauteur Höhe Altura	Capacità teglie GN 1/1 Capacity plates GN 1/1 Capacité plats GN 1/1 Fassungsvermögen Pfannen GN 1/1 Capacidad bandejas GN 1/1	Temperatura Temperature Température Temperatur Temperatura	Tensione Voltage Tension Spannung Voltaje	Potenza Power Puissance Leistung Potencia	Peso Weight Poids Gewicht Peso
FCE10-UM PR9	935 mm	705 mm	1130 mm	10	30° - 280°C	2x230V 3~/ 400V 3N~	2x5,7 KW	Kg 127