



CUOCI WURSTEL

Cuoci wurstel

Hot dog machines

Chauffe saucisses

Wurst-Dampfkocher und -bräter

Hot dog

Cuoci wurstel

Hot hot-dogs

Now as then-gyros!

There are pork hot dogs, pork and beef hot dogs, white veal hot dogs, and now dietetic hot dogs made of chicken and turkey and so on. Vapour cooked or roasted on the spit? Let your client decide. And the hot dog is ready in a twinkling with CB hot dog, yummy as ever. CB has a professional complete array for the satisfaction of every wurstel and bread lover!

- Steamed operated hot dog warmer with toaster
- Hot Dog roller grill with movement
- Uniformity of the cooking result

Hot hot-dogs

Chauffe saucisses

Il y a des saucisses exclusivement de porc, d'autres de bœuf et de porc, les saucisses blancs de veau, maintenant il existe même les saucisses diététiques au poulet, à la dinde et autres.

A la vapeur ou dorés? Le choix aux clients. Et l'hot dog est prêt dans un instant, appétissant comme à jamais. CB a une gamme professionnelle complète pour satisfaire les amateurs des saucisses et de son sandwich.

- Chauffe saucisses à vapeur avec grille-pains
- Chauffe saucisses avec mouvement rotatif
- Uniformité du résultat de cuisson

Hot Hot-dogs

Wurst-Dampfkocher und -bräter

Dampfgegart oder Geröstet, das ist hier die Frage. Ob Kalb, Schwein, Putenfleisch oder Rind - Würstchen, die Klassiker, die sich immer wieder aufs Neue erfinden. Eines bleibt jedoch beständig, unsere Kunden und auch Sie haben mit den CB Hot-Dog Maschinen den perfekten Schnitt für Ihr Würstchen. Wir verfügen über eine umfassende Produktserie, welche die Verehrer der Wurst und Ihrer Brötchen begeistern wird. Die passenden CB Brötchenröster runden unser Angebot für den perfekten Hot-Dog Geschmack ab.

- Wurstdampfkocher und Brötchenröster für Hot-Dogs
- Wurstbräter mit Drehbewegung
- Uniformes Garergebnis

Hot hot-dogs

Hot dog

Hay salchichas solo de cerdo, de carne de vacuno y cerdo, blancas de ternera y ahora las dietéticas de pollo y pavo y más. ¿Al vapor o a la parrilla? Sus clientes podrán elegir. Y el perrito caliente está listo en un segundo con CB hotdog, sabroso como nunca. CB tiene una gama profesional completa para satisfacer todos los palados enamorados de las salchichas y de su bocadillo.

- Calentador de salsichas de vapor con tostador
- Calentador de salsichas con movimiento rotatorio
- Uniformidad del resultado de cocción



Cuoci wurstel

Hot hot-dogs

Ci sono wurstel esclusivamente di suino, quelli di bovino e suino, quelli bianchi di vitello, ora anche quelli dietetici di pollo e tacchino e altro. Hot al vapore o arrostiti? Ai vostri clienti la scelta. E l'hot dog è pronto in un istante con CB hot dog appetitoso come non mai. CB ha all'attivo una gamma professionale completa per soddisfare tutti i palati innamorati dei wurstel e del loro panino!

- Scalda wurstel a vapore con tostapane
- Cuoci wurstel con movimento rotatorio
- Uniformità del risultato di cottura



Scopri l'azienda CB

Discover CB company
Découvrez l'entreprise CB
Entdecke die Firma CB
Descubre la empresa CB

Scalda wurstel a vapore e tostapane per hot dog

Steam operated hot dog warmers and bread toasters for hot dog SW, TP, P
Characteristics and advantages

- Steam operated hot dog warmer with aluminium teflonized water container
- Two superposed baskets to contain sausages to be warmed
- Skewers to toast bread in teflonized aluminium, containing a cartridge heating element (excluding SW1)

Chauffe saucisses à vapeur et grille-pains pour hot dog SW, TP, P
Caracteristiques and avantages

- Chauffe saucisses à vapeurs avec réservoir d'eau en aluminium téflonisé
- Deux paniers superposés pour contenir les saucisses à chauffer
- Plots chauffe-pain en aluminium téflonisé, avec résistances à cartouche (not pour SW1)

Wurstdampfkocher und Brötchenröster für Hot Dog SW, TP, P
Merkmale und Vorteile

- Wurstdampfkocher mit teflonbeschichteter Aluminium-Wasserschale
- Zwei übereinander gestapelte Körbe für die separate Warmhaltefunktion
- Mit Teflon beschichteten Brötchen-Heizstäben (ausgenommen SW1)

Calentador de salchichas a vapor y tostadoras de pan para hot dog SW, TP, P
Características y ventajas

- Calentador de salchichas a vapor con bandeja de agua de aluminio con teflón
- Dos cestas apiladas para contener las salchichas
- Punzones calentadores de pan, de aluminio recubierto de teflón, con resistencias de cartucho (excepto SW1)

SW, TP, P



Caratteristiche e vantaggi

- Scalda wurstel a vapore con vaschetta acqua in alluminio teflonato
- Due cestelli sovrapposti per contenere i wurstel da riscaldare
- Punzoni scalda pane in alluminio teflonato, contenenti resistenze a cartuccia (escluso SW1)

Cuoci wurstel a rulli

Hot dog roller grill W

Characteristics and advantages

- Rotary movement cooking, stainless steel tubes, available in teflon version
- Heating elements placed inside the tubes
- Thermostat regulator for cooking management
- Fat drip tray

Chauffe saucisses à rouleaux W

Characteristiques and avantages

- Cuisson avec mouvement rotatif, tubes en acier inox, disponible aussi dans la version téflonisée
- Résistances blindées à l'intérieur des tubes
- Thermostat réglable pour la gestion cuisson
- Bac pour recueillir la graisse

Wurstbräter W

Characteristics and advantages

- Drehrichtungsgaren aus Edelstahl, auch in der Teflon-Version erhältlich
- Einzelne rotierende Heizelemente
- Einstellbarer Thermostat für die Steuerung der Garprozesse
- Auffangschale

Calentadoras de salchichas W

Características y ventajas

- Tubos giratorios en acero inoxidable, disponible la versión de teflón
- Resistencias acorazadas dentro de los rodillos
- Regulación con termostato
- Bandeja recoge grasas

Cuoci wurstel



W



Caratteristiche e vantaggi

- Cottura a movimento rotatorio, tubi in acciaio inox, disponibile anche nella versione teflonata
- Resistenze corazzate poste all'interno dei tubi
- Termostato regolabile per gestione cottura
- Bacinella raccogli grasso

SERIE
LINE
SÉRIE
MODELL
SERIE

Cuoci wurstel

Scheda tecnica
Data sheet
Fiche technique
Technische Daten
Ficha técnica



SW1

Cod. 14100184



2P

Cod. 14100112



4P

Cod. 14100114



TP2

Cod. 14100124



TP4

Cod. 14100125



TP6

Cod. 14100126

MODELLO MODEL MODÈLE MODELL MODELO	SW1	2P	4P	TP2	TP4	TP6
LARGHEZZA WIDTH LARGEUR BREITE ANCHURA	245 mm	245 mm	245 mm	220 mm	220 mm	220 mm
PROFONDITÀ DEPTH PROFONDEUR TIEFE PROFUNDIDAD	330 mm	370 mm	470 mm	220 mm	220 mm	340 mm
ALTEZZA HEIGHT HAUTEUR HOHE ALTURA	400 mm	400 mm	400 mm	270 mm	270 mm	270 mm
N. PUNZONI NO. SKEWERS N. PLOTS NR. TOASTSTANGEN N°PUNZONES	-	2	4	2	4	6
TENSIONE VOLTAGE TENSION SPANNUNG VOLTAJE	230V~	230V~	230V~	230V~	230V~	230V~
POTENZA POWER PUISSANCE LEISTUNG POTENCIA	270 W	430 W	630 W	170 W	340 W	510 W
PESO WEIGHT POIDS GEWICHT PESO	6 Kg	7 Kg	8 Kg	2 Kg	3 Kg	4 Kg

SERIE
LINE
SÉRIE
MODELL
SERIE

Cuoci wurstel

Scheda tecnica
Data sheet
Fiche technique
Technische Daten
Ficha técnica



W12/5T

Cod. 14100356
*Cod. 14100356.TEF

W18/7T

Cod. 14100357
*Cod. 14100357.TEF

W24/5T

Cod. 14100437
*Cod. 14100437.TEF

W24/7T

Cod. 14100358
*Cod. 14100358.TEF

W32/9T

Cod. 14100359
*Cod. 14100359.TEF

W32/9S

Cod. 14100329
*Cod. 14100329.TEF

W52/14T

Cod. 14100613
*Cod. 14100613.TEF

MODELLO MODEL MODÈLE MODELL MODELO	W12/5T	W18/7T	W24/5T	W24/7T	W32/9T	W32/9S	W52/14T
LARGHEZZA WIDTH LARGEUR BREITE ANCHURA	450 mm	450 mm	560 mm	560 mm	560 mm	560 mm	560 mm
PROFONDITÀ DEPTH PROFONDEUR TIEFE PROFUNDIDAD	230 mm	300 mm	230 mm	300 mm	375 mm	375 mm	570 mm
ALTEZZA HEIGHT HAUTEUR HÖHE ALTURA	180 mm	180 mm	180 mm	180 mm	180 mm	180 mm	180 mm
N. RULLI NO ROLLERS N. ROULEAUX NR. ROLLEN N° RODILLOS	5	7	5	7	9	9	14
LARGHEZZA RULLI ROLLERS WIDTH LARGEUR ROULEAUX ROLLEN-BREITE ANCHURA RODILLOS	350 mm	350 mm	460 mm	460 mm	460 mm	460 mm	460 mm
TENSIONE VOLTAGE TENSION SPANNUNG VOLTAJE	230V~	230V~	230V~	230V~	230V~	230V~	230V~
POTENZA POWER PUISSANCE LEISTUNG POTENCIA	1100 W	1500 W	900 W	1350W	1650 W	1650 W	2800 W
PESO WEIGHT POIDS GEWICHT PESO	7 Kg	8 Kg	8 Kg	9 Kg	12 Kg	12 Kg	18 Kg

SERIE
LINE
SÉRIE
MODELL
SERIE

Cuoci wurstel

Dettagli dell'apparecchiatura
Machine details
Détails de la machine
Maschinen Details
Detalles de la maquina

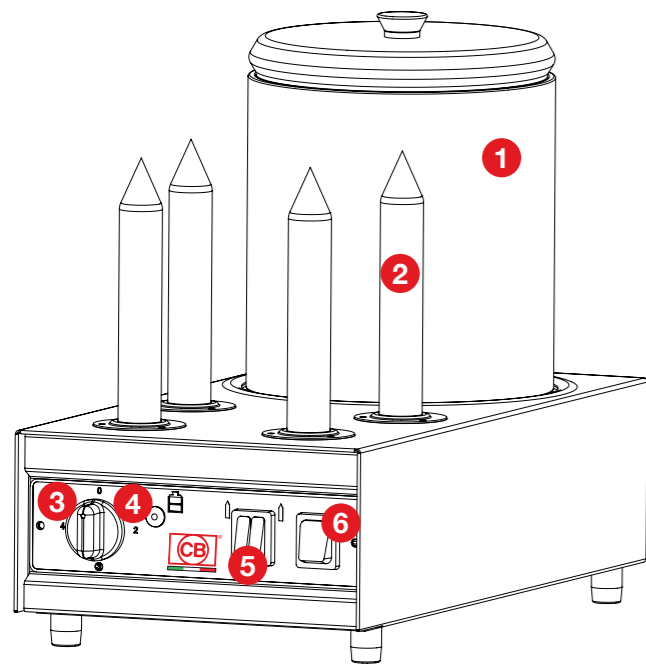

1. Scalda wurstel a vapore con vaschetta acqua in alluminio teflonato
2. Punzoni scalda pane in alluminio teflonato, contenenti resistenze a cartuccia
3. Regolatore di energia
4. Spia resistenze
5. Interruttore resistenze
6. ON/OFF

1. Steam operated hot dog warmer with aluminium teflonized water container
2. Skewers to toast bread in teflonized aluminium, containing a cartridge heating element
3. Power regulator
4. Heating element warning light
5. Heating elements switch
6. ON/OFF

1. Chauffe saucisses à vapeurs avec réservoir d'eau en aluminium téflonisé
2. Plots chauffe-pain en aluminium téflonisé, avec résistances à cartouche
3. Régulateur d'énergie
4. Voyant résistances
5. Interrupteur résistances
6. ON/OFF

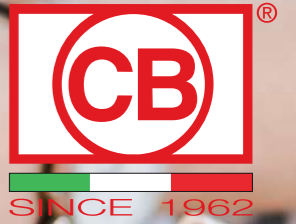

1. Wurstdampfkocher mit Teflon beschichteter Aluminium-Wasserschale
2. Mit Teflon beschichteten Brötchen-Heizstäbe
3. Energieregler
4. Widerstandsleuchte
5. Heizstäbeschalter
6. ON/OFF

1. Calentador de salchichas a vapor con bandeja de agua de aluminio con teflón
2. Punzones calentadores de pan, de aluminio recubierto de teflón, con resistencias de cartucho
3. Regulador de energía
4. Testigo resistencias
5. Interruptor resistencias
6. ON/OFF





CB SRL
Via Vienna, 41
24040 Bottanuco
Bergamo, Italy

 +39.035.499491 www.cb-italy.com
 +39.035.907545 info@cb-italy.com



MADE IN ITALY



La ditta CB si riserva il diritto di apportare qualsiasi modifica per il miglioramento delle sue apparecchiature.
The company CB reserves the right to make amendments to its equipment in order to improve it.
Document non contractuel. La CB pratique une politique d'amélioration permanente et se réserve le droit de modifier ses appareils sans notification préalable.
Das Unternehmen CB behält sich vor, Änderungen oder Ergänzungen der bereitgestellten Informationen oder Daten vorzunehmen.
La empresa CB se reserva el derecho a realizar modificaciones para mejorar sus aparatos.

Le fotografie rappresentate contengono optional
Pictures are shown with accessories
Les photos représentées sont avec des options
Die Produktbilder sind mit Zubehör abgebildet
Las fotografías muestran los elementos opcionales